



## PANINI GRILL

IMPORTANT INSTRUCTIONS  
SAVE THESE INSTRUCTIONS

## GRILL A CONTACT

MODE D'EMPLOI IMPORTANT  
CONSERVEZ LES PRESENTES INSTRUCTIONS

## PARILLA A CONTACTO

INSTRUCCIONES DE USO  
GUAREDE ESTAS INSTRUCCIONES  
LEA CUIDADOSAMENTE ESTE INSTRUCTIVO  
ANTES DE USAR SU APARATO

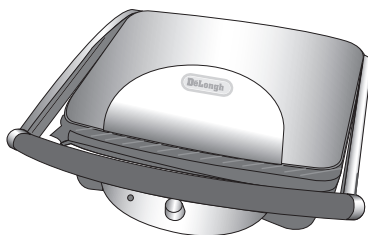

### TYPE/MODÈLE/TIPO CGH800

Register this product on-line and receive a free trial issue of Cook's Illustrated. Visit [www.delonghi.com](http://www.delonghi.com)  
Visit [www.delonghi.com](http://www.delonghi.com) for a list of service centers near you. (U.S. Only)

Enregistrez ce produit en ligne et recevez un numéro gratuit de Cook's Illustrated.  
Visitez [www.delonghi.com](http://www.delonghi.com)  
Visitez [www.delonghi.com](http://www.delonghi.com) pour y voir une liste des centres de réparation proches de chez vous. (É.-U. uniquement)

Registre este producto en línea y reciba un ejemplar gratis de Cook's Illustrated.  
Visite [www.delonghi.com](http://www.delonghi.com)  
Visite [www.delonghi.com](http://www.delonghi.com) para ver la lista de centros de servicios cercanos a usted. (Solamente en los Estados Unidos)

ELECTRIC CHARACTERISTICS/ CARACTÉRISTIQUES ÉLECTRIQUES  
CARACTERISTICAS ELECTRICAS  
120 V~ 60 Hz 1 500 W

*Thank you for purchasing a De'Longhi product.  
De'Longhi is well known throughout Europe  
and the world for its high-quality,  
long-lasting Italian designed products.  
We are sure that you will enjoy your De'Longhi  
product for many years to come.  
If you have any questions or comments regarding  
your new De'Longhi product, or any of our products, please feel free to contact us at:  
1-800-322-3848  
We will be happy to answer any questions you have.*

*Nous vous remercions d'avoir choisi  
un produit De' Longhi.  
De' Longhi est une marque connue en Europe  
et dans le monde entier pour sa haute qualité,  
et pour ses produits durables et au design italien.  
Nous sommes certains que vous apprécierez v  
otre appareil De' Longhi  
pendant de nombreuses années.*

*Les agrademos que hayan adquirido  
un producto De' Longhi.  
De' Longhi es una marca conocida en Europa  
y en todo el mundo  
por su elevada calidad,  
por sus productos de larga duración en el tiempo  
y por su diseño italiano.  
Estamos seguros de que se alegraran  
de su producto De' Longhi  
por muchos años.*

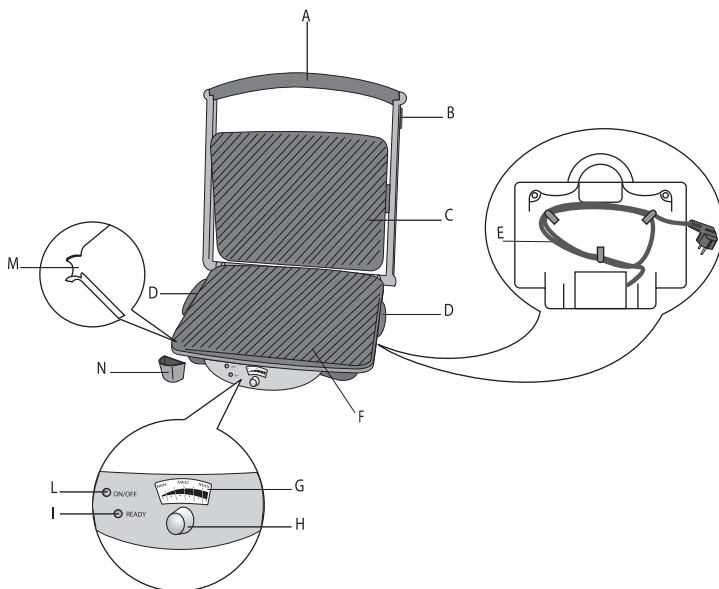

**EN**

**DESCRIPTION OF APPLIANCE**

- A** Handle
- B** Grill plate release catch
- C** Non-stick top grill plate
- D** Handgrip
- E** Cord wrap
- F** Non-stick bottom grill plate
- G** Cooking level indicator
- H** Thermostat knob
- I** "READY" indicator light
- L** "ON/OFF" indicator light
- M** Oil and grease drainage
- N** Oil and grease drainage cup

**FR**

**DESCRIPTION DE L'APPAREIL**

- A** Poignée
- B** Clip de verrouillage
- C** Plaque supérieure anti-adhésive
- D** Poignées pour manipuler l'appareil
- E** Range-cordon
- F** Plaque inférieure anti-adhésive
- G** Indicateur de cuisson
- H** Bouton thermostat
- I** Voyant lumineux "READY"
- L** Voyant lumineux "ON/OFF"
- M** Écoulement des graisses
- N** Bac à graisses

**ES**

**DESCRIPCION DEL APARATO**

- A** Asa
- B** Gancho de cierre
- C** Plancha superior antiadherente
- D** Empuñadura
- E** Portacable
- F** Plancha inferior antiadherente
- G** Indicador de grado de cocción
- H** Mando del termostato
- I** Lámpara piloto "READY"
- L** Lámpara piloto "ON/OFF"
- M** Salida grasa
- N** Recipiente recoge grasa

**Pos.1**

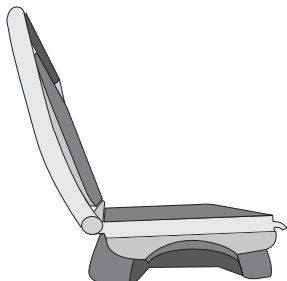

**Pos.2**



## IMPORTANT INSTRUCTIONS

When using electrical appliances, basic safety precautions should always be followed, including the following:

1. Read all instructions.
2. Do not touch hot surfaces. Use handles or knobs as the outer surface may become very hot during use.
3. To protect against electrical shock, do not immerse cord, plugs or any part of the unit in water or other liquid.
4. Close supervision is necessary when any appliance is used by or near children.
5. Unplug from outlet when not in use and before cleaning. Allow to cool before putting on or taking off parts, and before cleaning the appliance.
6. Do not operate any appliance with a damaged cord or plug or after the appliance malfunctions, or has been damaged in any manner. Return appliance to the nearest authorized service center for examination, repair or adjustment.
7. The use of accessory attachments not recommended by the appliance manufacturer may cause injuries.
8. Do not use outdoors.
9. Do not let cord hang over edge of table or counter, or touch hot surfaces.
10. Do not place on or near a hot gas or electric burner, or in a heated oven.
11. To disconnect turn any control to "Off", then remove plug from wall outlet.
12. Do not use this appliance for other than intended use.
13. DO NOT IMMERSE IN WATER.

**WARNING: charcoal or similar combustible fuels must not be used with this appliance.**

14. Do not move the appliance when the oil is hot, as this risks causing serious burns.
15. A fire may occur if the appliance is covered or touching flammable material, including curtains, draperies, walls and the like when in operation. Do not store any item on top of the appliance when in operation.

## SAVE THESE INSTRUCTIONS For Household use only

### SHORT CORD INSTRUCTIONS

A short power cord is provided to reduce the risk resulting from entanglement or tripping over a longer cord. Longer detachable power supply cords are available and may be used if care is exercised in their use. If a longer detachable power cord or extension cord is used the marked electrical rating of the extension cord should be at least as great as the electrical rating of the appliance, and the longer cord should be arranged so that it will not drape over the countertop or table top where it can be pulled on by children or tripped over unintentionally.

If your product is equipped with a polarized alternating current line plug (a plug having one blade wider than the other), this plug will fit into the power outlet only one way. This is a safety feature. If you are unable to insert the plug fully into the outlet, try reversing the plug. If the plug should still fail to fit, contact your electrician to replace your obsolete outlet. Do not defeat the safety purpose of the polarized plug.

## INSTALLING THE GRILL

1. Before using the grill, make sure that it has not been damaged in any way during transportation.
2. Place the appliance on a flat surface well out of the reach of children, as high temperatures are generated during use.
3. Before plugging the appliance into the outlet, check that:
  - the supply voltage corresponds to that indicated on the rating plate fitted on the appliance;
  - the power on the outlet is minimum 12,5 A;
  - the outlet is suitable for the type of plug fitted on the appliance; if not it should be changed;
  - **the outlet is grounded.** The manufacturer does not accept any liability for damage caused as a result of non-compliance with this requirement (only for Canada).
4. Before using the grill for the first time, switch it on and let it heat up in the barbecue grill position (pos.1) without any food, for at least 5 minutes; open the window in order to eliminate any unpleasant smell that tends to be given off when an appliance is new.

## USING THE APPLIANCE

- Plug into the outlet and adjust the thermostat (H) to the required position. The ON/OFF indicator light (L) will come on. Pre-heat the appliance with the grill plates closed.
- When the appliance has reached the required temperature, the "READY" indicator light (I) will come on.
- Place the food to be grilled on the grill plates.
- Place the oil and grease drainage cup (N) under the oil and grease drainage channel.
- To turn the appliance off, turn the thermostat knob counter-clockwise until it stops **and unplug from the outlet.**
- After cooking, unplug the appliance and leave to cool.
- The release catch (B) enables the appliance to be closed (position 2) for easy transport.
- The appliance has a hinged top plate to adapt to foods of any thickness.

***Never touch the plates with sharp implements as this could damage the coating.***

## COOKING TIPS

- Thawed and marinated meat should be dried thoroughly before being placed on the grill.
- Meat should be seasoned before grilling but salt can be added at time of serving.
- Food which is to be contact-grilled should be uniformly thick to ensure even browning.
- When cooking fish, the bottom plate (F) must always be greased.
- A number of recipes suitable for the grill have been provided.

**Please note that the cooking times given are only approximate.**

They may vary, depending on the food being cooked (temperature prior to cooking, water content) and individual preference.

## CLEANING

**CAUTION:** make sure your grill is unplugged and cooled before attempting to clean. To protect against electric shock, do not immerse cord, plug or unit in water or other liquid.

1. The outside of your grill can be cleaned by wiping the surface with a damp, soft cloth.

**CAUTION:** never immerse the grill in water or other liquid.

2. Clean the grill plates by wiping the surface with a damp, soft cloth.  
Clean the oil and grease drainage cup with warm water and mild detergent.  
Rinse and dry thoroughly.

<b>FOOD</b>	<b>TEMP. SETTING</b>	<b>GRILL POSITION</b>	<b>TIME</b>	<b>REMARKS AND TIPS</b>
Pork Chops (1)	max	2	6'-8'	Pork chops should be of even thickness.
Hamburger (2)	max	2	3'-5'	Wait 2-3' before opening the plate, otherwise the burgers will break up.
Steak (1)	med	2	2'-3'	Meat cooked rare in time indicated
Pork steak (1)	max	2	2'-3'	Meat cooked rare in time indicated
Spare ribs (3)	max	1	15'-18'	Turn ribs after 10'
Liver (2)	med	2	2'-3'	Clean liver thoroughly
Kebabs (3)	max	1	8'-10'	Turn after 4-5'
Chicken (1 kg)	med	2	75'-80'	Cut open in half, do not turn
Sausage (3)	max	2	3'-5'	Cut in half
Fresh sausage (2)	max	2	4'-6'	Cut in half
Salmon trout fillet (1)	med	1	16'-20'	Grease the plate and turn halfway through cooking
Salmon steak (1)	med	1	16'-20'	Grease the plate and turn halfway through cooking
Sole (1)	med	1	18'-22'	Grease the plate and turn halfway through cooking
Eggplant (6 slices)	med	2	6'-8'	Slice evenly
Zucchini (7 slices)	med	2	6'-8'	Slice evenly
1 pepper/capsicum (quarters)	med	2	6'-8'	Close the grill plates and press down
Onions (sliced)	med	2	6'-8'	Slice evenly
Polenta (slices)	med	2	20'-25'	Cut into 1.5 cm (1/2 inch) thick slices. Leave to cook with plates closed for 15'
Filled bread rolls	med	2	3'-9'	Use soft rolls
Toasted sandwich/Panini	med	2	2'-3'	Place only half a cheese slice in each sandwich as it tends to spill as it melts.



## LIMITED WARRANTY

**This warranty applies to all products with De'Longhi or Kenwood brand names.**

### **What does the warranty cover?**

We warrant each appliance to be free from defects in material and workmanship. Our obligation under this warranty is limited to repair at our factory or authorized service center of any defective parts or part thereof, other than parts damaged in transit. In the event of a products replacement or return, the unit must be returned transportation prepaid. The repaired or new model will be returned at the company expense.

This warranty shall apply only if the appliance is used in accordance with the factory directions, which accompany it, and on an Alternating current ( AC ) circuit.

### **How long does the coverage last?**

This warranty runs for one year (1) from the purchase date found on your receipt and applies only to the original purchaser for use.

### **What is not covered by the warranty?**

The warranty does not cover defects or damage of the appliance, which result from repairs or alterations to the appliance outside our factory or authorized service centers, nor shall it apply to any appliance, which has been subject to abuse, misuse, negligence or accidents. Also, consequential and incidental damage resulting from the use of this product or arising out of any breach of contract or breach of this warranty are not recoverable under this warranty. Some states do not allow the exclusion or limitation of incidental or consequential damage, so the above limitation may not apply to you.

### **How do you get service?**

If repairs become necessary, see contact information below:

**U.S. Residents:** Please contact our toll free hotline at 1-800-322-3848 or log onto our website at [www.delonghi.com](http://www.delonghi.com)

**Residents of Canada:** Please contact our toll free hotline at 1-888-335-6644 or log onto our website at [www.delonghi.com](http://www.delonghi.com)

**Residents of Mexico:** Please contact our toll free number 01-800-711-8805 for assistance or log onto our website at [www.delonghi.com](http://www.delonghi.com)

The above warranty is in lieu of all other express warranties and representations. All implied warranties are limited to the applicable warranty period set forth above. This limitation does not apply if you enter into an extended warranty with De'Longhi. Some states/countries do not allow limitations on how long an implied warranty lasts, so the above exclusions may not apply to you. De'Longhi does not authorize any other person or company to assume for it any liability in connection with the sale or use of its appliance.

### **How does country law apply?**

This warranty gives you specific legal rights, and you may also have other rights, which vary from state to state/country to country.