

SAFETY INSTRUCTIONS

Read all the instructions carefully before using the appliance.

Keep these instructions



Please note:

This symbol highlights advice and important information for the user.

- Before using the oven for the first time, remove any paper and other material inside of it such as protective cardboard, booklets, plastic bags, etc.
- Make sure the appliance has not been damaged during transport.
- The appliance must be kept at a distance of at least 20 cm from the mains power socket to which it is connected.
- Before using for the first time, operate the oven empty with the thermostat at maximum and in CONVECTION mode for at least 30 minutes to eliminate the “new” smell and any smoke caused by the presence of protective substances applied to the heating elements before transport. Air out the room.
- Do not use on surfaces that can be damaged by heat.
- The oven must be located indoors, in an area without air currents and away from sources of heat and direct sunlight.
- Wash all accessories thoroughly before using, by hand or in the dishwasher, except for the crumb tray which must be washed by hand.
- The oven is equipped with a timer reset system in case of power outages up to 5 s.



Warning!

Failure to heed the warnings could cause injuries or damage to the appliance.

- This oven is designed to cook food. It must never be used for other purposes and must not be modified or tampered with in any way.
- Once the appliance is removed from the packaging, make sure the door is intact and functioning properly. Since it is made of glass, the oven door is fragile. If it is visibly chipped, scored or scratched it should be replaced. Avoid slamming or violently bumping the door while using, cleaning, or moving the appliance. Do not pour cold liquids on the glass when the appliance is hot.
- Place the appliance on a level surface at least 85 cm high and out of reach of children.
- The appliance may be used by children no younger than 8 years of age and in-

dividuals with reduced physical, sensory, or mental capacities or those without experience or the necessary knowledge as long as they are supervised or after they have received instructions regarding the safe use of the appliance and have understood its inherent dangers. Supervise children, making sure they do not play with the appliance. Cleaning and maintenance performed by the user may not be performed by children unless they are over 8 years of age and are constantly supervised.

- Keep the appliance and power cable out of the reach of children under 8 years of age.
 - Do not move the appliance while in use.
 - Do not use the appliance if:
 - The power cable is faulty
 - The appliance has been dropped, is visibly damaged or malfunctions. In these cases, to avoid all risk take the appliance to your nearest authorised customer service centre.
 - Never position the appliance near heat sources.
 - Do not use the appliance as a heat source.
 - Never place paper, cardboard or plastic inside the oven and never rest anything on top of the appliance (utensils, wire racks, other objects).
 - Do not insert anything in the air vents, which are located on the top and back of the appliance. Make sure they are not obstructed.
 - This oven is not designed for built-in installation.
 - Never rest heavy objects, hot dishes or containers on the door when it is open. Do not pull the handle down.
 - Professional or inappropriate use, or failure to observe the instructions absolves the manufacturer from all responsibility and invalidates the warranty.
- This is a household appliance only. It is not intended for use in staff kitchen areas in shops, offices and other working environments; agritourisms, hotels, mo-

tels and other residential type environments; bed and breakfast type environments.

- When not in use and before cleaning, always unplug the appliance.
- The appliance must not be operated by a timer or a separate remote control system.
- The appliance must be placed and operated with the back next to the wall.
- Do not use angular or sharp objects to clean the pan.
- Before cleaning, always turn the appliance off and unplug it from the mains socket.
- This project was not designed to store food.

The cooking accessories are not suitable for storing foods, especially if they are acidic. Avoid leaving acidic substances such as lemon juice or vinegar on the surface of the cooking accessories. Acidic substances such as lemon juice, tomato sauce, vinegar, and the like can corrode and ruin the coating.

Danger of burns!

Failure to heed these warnings could cause scalding or burns.

- When in operation, the door and accessible external surfaces could become very hot. Always use the knobs, handles and buttons. Never touch metal parts or the glass. Use oven gloves if necessary.
- This electrical appliance operates at high temperatures which could cause burns.
- Do not leave flammable products near the oven or under the work surface where it is located.
- Never operate the appliance under a wall cupboard or shelf or near inflammable materials such as curtains, blinds, etc.
- **If food or other parts of the oven catch fire, never try and put out the flames with water. Close the door, unplug from the mains and smother the flames with a damp cloth.**

Danger!

Failure to heed these warnings could lead to injury from electrical



shock and risk of death.

- **Before plugging into the mains, make sure that:**
 - **The mains voltage corresponds to the voltage indicated on the rating plate.**
 - **The mains socket has a minimum rating of 16A and an earth wire.**
- **The manufacturer declines all liability if this important accident-prevention rule is not respected.**
- Do not let the power cable dangle and keep it from touching hot parts of the oven. Never unplug the appliance by pulling on the power cable.
- If you intend to use an extension cord, make sure it is in good condition, that the plug is earthed and that the cross section of the wires is at least equal to that of the power cable provided with the appliance.
- In order to prevent electrical shocks, never submerge the power supply, plug, or entire appliance in water.
- If the power cable is damaged, it must be replaced by the manufacturer, the manufacturer's service centre or a qualified electrician in order to eliminate all risk.
- To protect personal safety, do not dismantle the appliance. Always contact the help centre.



This product is compliant with CE Regulation no. 1935/2004 regarding materials and objects intended for contact with food products.

APPLIANCE DESCRIPTION

A	Top heating element
B	Internal light
C	Glass door
D	Grills
E	Pan
F	Display
G	Timer knob ☺
H	START button
I	Red operation light
L	Internal temperature control button 
M	Temperature/weight adjustment knob 
N	On/stand-by button 
O	Function selection knob FUNCTION
P	Bottom heating element
Q	Pizza plate
R	Crumb tray
S	Fan heating element (not visible)

DISPLAY

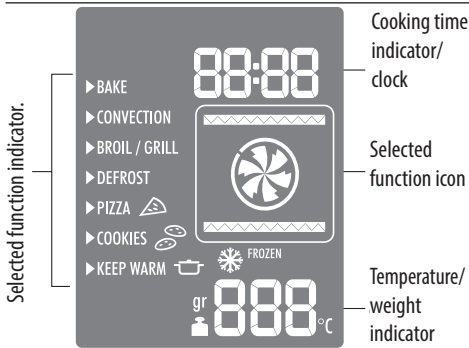

TECHNICAL DATA

Voltage: 220-240 V ~ 50/60Hz

Absorbed power: 2000 W

Dimensions LxHxD; 490x445x300

Weight: 11.586 Kg

INSTALLATION AND FIRST USE

- Before using the oven for the first time, remove any paper and other material inside of it such as protective cardboard, booklets, plastic bags, etc.
- Make sure the appliance has not been damaged during transport.
- Place the appliance on a flat, solid surface- Remove any object from above the appliance. Do not use on surfaces that can be damaged by heat.
- Wash all accessories thoroughly before using, by hand or in the dishwasher, except for the crumb tray which must be washed by hand.

The crumb tray must be inserted in the oven, at the bottom of the chamber, below the bottom heating element.

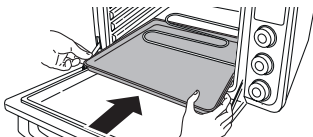

- The appliance must be kept at a distance of at least 20 cm from the mains power socket to which it is connected. Before operating the appliance, move it 10 cm away from the wall and any object found on the same work surface.

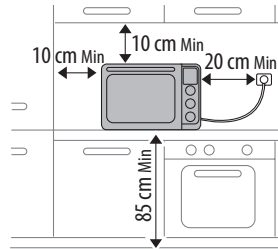

- Before using for the first time, operate the oven empty with the thermostat at maximum and in CONVECTION mode for at least 30 minutes to eliminate the "new" smell and any smoke caused by the presence of protective substances applied to the heating elements before transport. Air out the room.

SETTING THE CLOCK

When the appliance is connected to the power outlet for the first time or after a power outage, it emits a beep and the display shows four lines ("--:--"). After 5 seconds the display turns off since the time of day has not been set and the appliance goes into stand-by mode. To set the clock, proceed as follows:

Press the START button (H) for at least 3 seconds (fig. 2).

The time will start to flash (00:00).

Set the time by turning the ⌚ timer knob (G) (13:00).

Press the START button (H).

The minutes will start to flash (13:00).

Adjust the minutes by turning the ⌚ timer knob (G) (13:25).

Press the START button (H).

The set time is displayed (13:25).

If you wish to change the time later, repeat the procedure above. The appliance must be in stand-by mode in order to be able to change the time.



BAKE FUNCTION (TRADITIONAL COOKING)

This function is ideal for cooking lasagna, cannelloni, and cakes in general...

- Press the on/stand-by button (N).

The oven turns on.

When the oven is on, if no knob is turned or no button is pressed, it turns off after 2 minutes and goes into stand-by mode.

- The automatically selected function that appears on the display is BAKE (Traditional cooking).

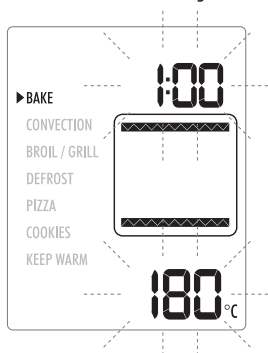

The values that can be changed, cooking time and temperature, flash. If these values are not set, the display will show 1:00 h and 180°C.

- Turn the temperature/weight adjustment knob (M) to adjust the temperature (from a minimum of 80°C to a maximum of 220°C).
- Turn the timer (G) to set the cooking time (from a minimum of 0:01 minutes to a maximum of 2:00 hours).
- Press the START button (H) to start the pre-heating phase. The red light (I) around the START button (H) lights up and the display shows PRE-HEAT.

- When the oven reaches the set temperature, a beep is heard. The previously set cooking time begins to count down.
- Open the oven door and insert the food to be cooked on the grill (D) or in the pan (E) in position 1 or 2.

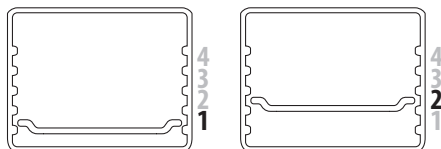

- Close the door.
- When the cooking time has ended, the display will show END and the oven will beep.
- To reset the oven, during operation or at the end of cooking when END appears on the display, press the on/stand-by button (N) for 2 seconds.
- Open the oven door and remove the food using oven gloves.

When the BAKE function (traditional cooking) is active, the function can be changed to CONVECTION (ventilated cooking) or BROIL/GRILL without interrupting cooking. Simply turn the function selector knob FUNCTION (O) to select the new function desired. The cooking time and temperature remain those that were set previously. For the BROIL/GRILL function the temperature is set automatically.

FOODS	WEIGHT	POSITION GRILLS/PAN	TEMPERATURE	TIME (minutes)
cannelloni	1000 g	grill in pos. 1	180 °C	35-40
fish	1000 g	pan in pos. 2	200° C	30-35
tomato gratin	1000 g	pan in pos. 2	200° C	25-30
sponge cake	700 g	grill in pos. 1	170 °C	25-30
ring cake	750 g	grill in pos. 1	180 °C	30-35
jam tart	1000 g	pan in pos. 2	180 °C	30-35
plum cake	900 g	grill in pos. 1	150 °C	85-90
muffins	12	pan in pos. 2	170 °C	20-25



CONVECTION FUNCTION (VENTILATED COOKING)

This function is ideal for cooking quiches, poultry, potatoes, puff pastries...

- Press the on/stand-by button (N).
The oven turns on.
When the oven is on, if no knob is turned or no button is pressed, it turns off after 2 minutes and goes into stand-by mode.
- The automatically selected function that appears on the display is BAKE (Traditional cooking).
- Turn the FUNCTION knob (O) to select the CONVECTION mode.
The values that can be changed, temperature and cooking time, flash. If these values are not set, the display will show 1:00 h and 180°C.

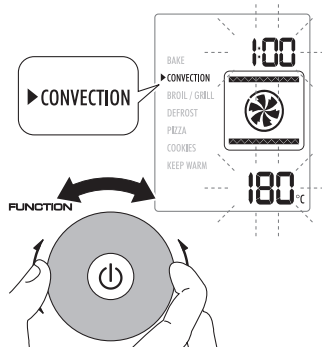

- Turn the temperature/weight adjustment knob (M) to adjust the temperature (from a minimum of 80°C to a maximum of 220°C).

- Turn the timer knob (G) to set the cooking time (from a minimum of 0:01 minutes to a maximum of 2:00 hours).
- Press the START button (H) to start the pre-heating phase. The red light (I) around the START button (H) lights up and the display shows PRE-HEAT.
- When the oven reaches the set temperature, a beep is heard.
The previously set cooking time begins to count down.
- Open the oven door and insert the food to be cooked on the grill (D) or in the pan (E) in position 1 or 2.

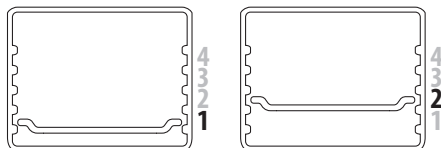

- Close the door.
- When the cooking time has ended, the display will show END and the oven will beep.
- To reset the oven, during operation or at the end of cooking when END appears on the display, press the on/stand-by button (N) for 2 seconds.
- Open the oven door and remove the food using oven gloves.

When the CONVECTION function (ventilated cooking) is active, the function can be changed to BAKE (traditional cooking) or BROIL/GRILL without interrupting cooking. Simply turn the FUNCTION knob (O) to select the new function desired.

The cooking time and temperature remain those that were set previously. For the BROIL/GRILL function the temperature is set automatically.

FOODS	WEIGHT	POSITION GRILLS/PAN	TEMPERATURE	TIME (minutes)
bun	500 g	pan in pos. 2	170 °C	35-40
savoury pie	700 g	grill in pos. 1	180 °C	30-35
whole chicken	2500 g	pan in pos. 1	180 °C	90-100
chicken in pieces	1500 g	pan in pos. 1	180 °C	40-45
kebab	1000 g	pan in pos. 2	170 °C	55-60
roast	1000 g	pan in pos. 1	180 °C	75-80
frozen potatoes	1000 g	pan in pos. 2	190 °C	55-60
fresh potatoes	1000 g	pan in pos. 2	190 °C	50-55
frozen brioches	6 pc	pan in pos. 2	160 °C	25-30



BROIL/GRILL FUNCTION (GRILL COOKING)

This function is ideal for cooking fillets, sausages, and ribs or for gratin baking...

- This function does not require pre-heating.
 - Place the food on the grill (D) and insert it in the oven along with the pan (E).
- The pan (E) and the grill (D) must be positioned as shown in the figure (positions 3 and 4).

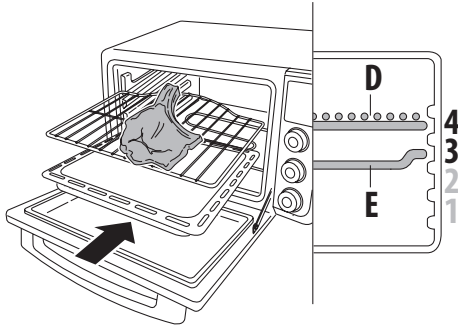

- Close the door.
 - Press the on/stand-by button (N).
The oven turns on.
- When the oven is on, if no knob is turned or no button is pressed, it turns off after 2 minutes and goes into stand-by mode.
- The automatically selected function that appears on the display is BAKE (Traditional cooking).
 - Turn the FUNCTION knob (O) to select BROIL/GRILL mode; the display shows BRL and the value that can be changed for the cooking time flashes. If this value is not set, the display will show 0:30 minutes.

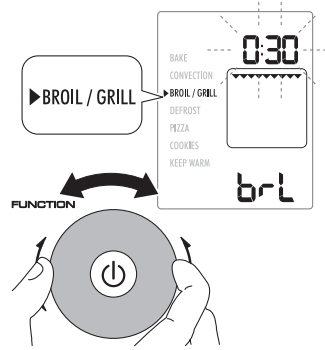

- In this function the temperature is set automatically.
- Turn the timer knob (G) to set the cooking time (from a minimum of 0:01 minutes to a maximum of 2:00 hours).
- Press the START button (H) to start cooking.
The red light (I) around the START button (H) lights up.
- Turn the food mid-way through cooking.
- When the cooking time has ended, the display will show END and the oven will beep.
- To reset the oven, during operation or at the end of cooking when END appears on the display, press the on/stand-by button (N) for 2 seconds.
- Open the oven door and remove the food using oven gloves.

When the BROIL/GRILL function is active, the function can be changed to BAKE (traditional cooking) or CONVECTION (ventilated cooking) without interrupting cooking.

Simply turn the FUNCTION knob (O) to select the new function desired.

The cooking time remains as set previously and the temperature is set automatically (180°C)

FOODS	WEIGHT	POSITION GRILLS/PAN	TEMPERATURE	TIME (minutes)
neck fillet	3 pc	grill in pos. 4 pan in pos. 3	auto	25-30
sausage	400 g	grill in pos. 4 pan in pos. 3	auto	20-25
lamb chops	4 pc	grill in pos. 4 pan in pos. 3	auto	15-20



PIZZA FUNCTION

This function is ideal for cooking fresh or frozen pizzas.

- It is an automatic function that incorporates preset programs.
- In the PIZZA function the cooking time and temperature are set automatically. So it is possible to add a few minutes at the end of cooking if necessary.
- Position the pizza on the pizza plate (Q), set it all on the grill (D) and insert it in the oven in position 1.

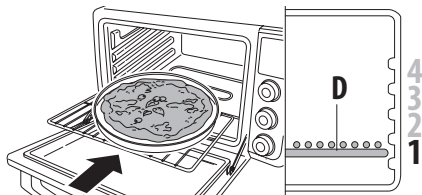

- Close the door.
- Press the on/stand-by button (N). The oven turns on. When the oven is on, if no knob is turned or no button is pressed, it turns off after 2 minutes and goes into stand-by mode. The automatically selected function that appears on the display is BAKE (Traditional cooking).
- Turn the FUNCTION knob (O) to select the PIZZA mode. The value that can be changed for the weight of the pizza flashes.

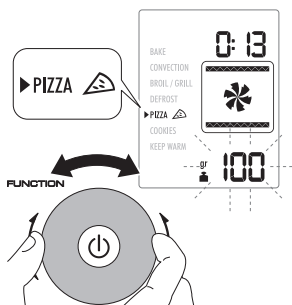

- Turn the temperature/weight knob (M) to set the weight of the pizza (from a minimum of 100g to a maximum of 900g)

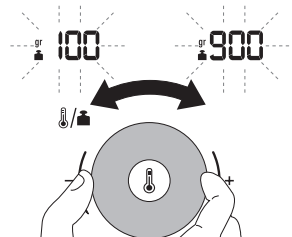

and to also select the type of pizza to be cooked: "fresh" or "frozen" (❄️ FROZEN).

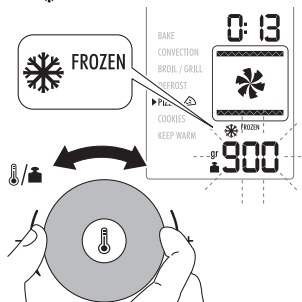

- Press the START button (H) to start cooking. The red light (I) around the START button (H) lights up.
- While cooking "fresh" pizza, a beep notifies you when you can open the oven door to add mozzarella to the pizza. This does not occur while cooking "frozen" pizza (❄️ FROZEN).
- Close the door and wait for the cooking phase to finish.
- It is possible to cook two "frozen" pizzas (❄️ FROZEN) at the same time by placing directly on the two grills (D) as shown in the figure (position 1 and 3).

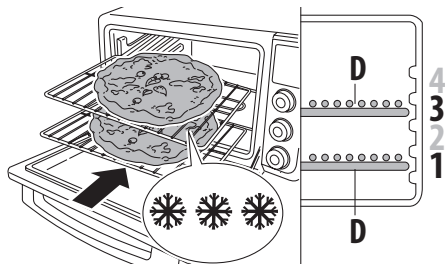

Mid-way through cooking, swap the position of the two grills.

- When the cooking time has ended, 00:00 flashed on the display and the oven beeps. It is possible to add up to 10 minutes if necessary. If no time is set within 5 minutes, the oven resets automatically. If additional time is set, once it is finished "END" appears on the display.
- To reset the oven, during operation or at the end of cooking, press the on/stand-by button (N) for 2 seconds.
- Open the oven door and remove the two pizzas using oven gloves.



COOKIES FUNCTION (BISCUITS)

This function is ideal for cooking delicious biscuits...

- It is an automatic function that incorporates preset programs.
- In this function, the cooking time and temperature are set automatically.

It is still possible to change the cooking time by turning the timer knob ☺ (G).

- Press the ⏻ on/stand-by button (N).
The oven turns on. When the oven is on, if no knob is turned or no button is pressed, it turns off after 2 minutes and goes into stand-by mode.

The automatically selected function that appears on the display is BAKE (Traditional cooking).

- Turn the FUNCTION knob (O) to select COOKIES mode; the display shows "1P" that is flashing.

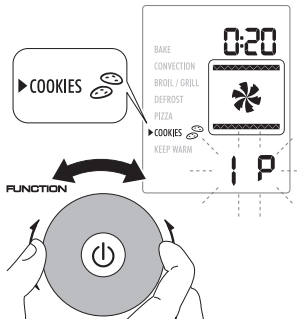

- Turn the temperature/weight adjustment knob 🌡️/🍪 (M) to select the quantity of biscuits to be cooked: "1P" to cook biscuits positioned on a single level or "2P" to cook two levels at the same time.

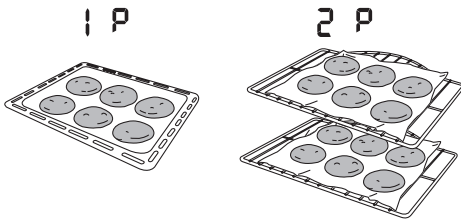

- Press the START button (H) to start the pre-heating phase. The red light (I) around the START button (H) lights up and the display shows PRE-HEAT.
- When the oven reaches the set temperature, a beep is heard. The cooking time and red light (I) flash.
- Open the oven door, set the biscuits in the pan (E) (to cook biscuits in a single level) and insert everything in the oven in position 2.

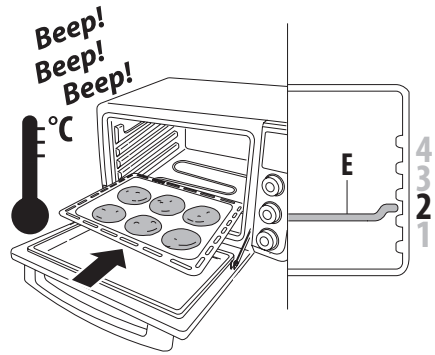

- It is possible to cook biscuits in two levels at the same time by positioning the biscuits directly on the two grills (D) using baking paper and inserting everything inside the oven in position 1 and 3. In the middle of cooking, the red function light (I) flashed and a beep signals that it is necessary to swap the position of the two grills.

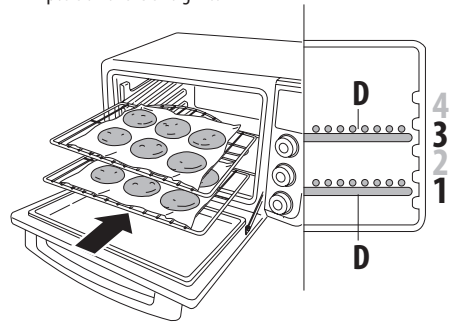

- Close the door.
- Press the START button (H) to continue cooking.
- When the cooking time has ended, the display will show 00:00 and the oven will beep.

It is possible to add up to 10 minutes if necessary. If no time is set within 5 minutes, the oven resets automatically. If additional time is set, once it is finished "END" appears on the display.

- To reset the oven, during operation or at the end of cooking, press the on/stand-by button ⏻ (N) for 2 seconds.
- Open the oven door and remove the pan (E) or the two grills (D) using oven gloves.



KEEP WARM

- Set the previously cooked food on the grill (D) or in the pan (E) and insert it in the oven in position 1.

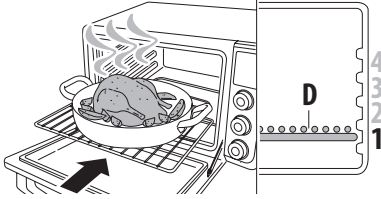

- Close the door.
- Press the on/stand-by button (N).
The oven turns on. When the oven is on, if no knob is turned or no button is pressed, it turns off after 2 minutes and goes into stand-by mode.
The automatically selected function that appears on the display is BAKE (Traditional cooking).
- Turn the FUNCTION knob (O) to select the KEEP WARM mode. The value that can be changed for the keep warm time flashes.

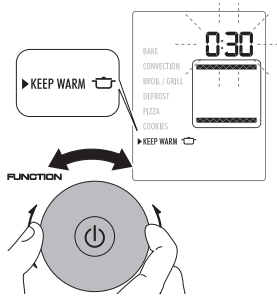

- Turn the timer knob (G) to set the keep warm time (from a minimum of 0:01 minutes to a maximum of 2:00 hours). In this function the temperature is set automatically.
- Press the START button (H) to start the keep warm function.
The red light (I) around the START button (H) lights up.
- When the keep warm time has ended, the display will show END and the oven will beep.
- To reset the oven during operation or at the end for the set keep warm time, when the display shows END, press the on/stand-by button (N) for 2 seconds.
- Open the oven door and remove the food using oven gloves.

Slow cooker

The KEEP WARM function, with its precise low temperature, can also be used as a slow cooker. In this function the cooking time

can be set for up to 6 hours.



DEFROST FUNCTION

This function is ideal for defrosting food...

Before using this function, make sure the oven is completely cold.

- Set the food to be defrosted on the grill (D) or in the pan (E) and insert it in the oven in position 1.

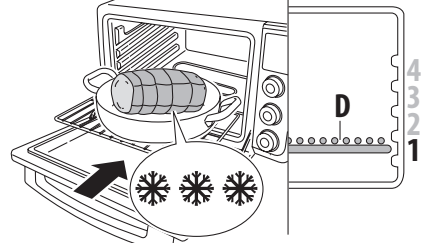

- Close the door.
- Press the on/stand-by button (N).
The oven turns on. When the oven is on, if no knob is turned or no button is pressed, it turns off after 2 minutes and goes into stand-by mode.
- The automatically selected function that appears on the display is BAKE (Traditional cooking).
- Turn the FUNCTION knob (O) to select DEFROST mode; the display shows DEF ❄️ AND THE VALUE THAT CAN BE CHANGED for the cooking time flashes. If this value is not set, the display will show 0:30.

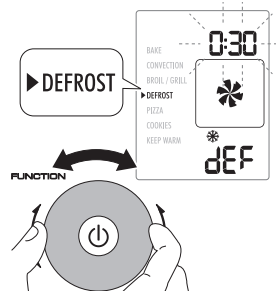

- Turn the timer knob (G) to set the defrosting time (from a minimum of 0:01 minutes to a maximum of 2:00 hours).
- Press the START button (H) to start the defrost cycle.
The red light (I) around the START button (H) lights up.
- When the defrosting time has ended, the display will show END and the oven will beep.
- To reset the oven, during operation or at the end of defrosting, when END appears on the display, press the on/stand-by button (N) for 2 seconds.
- Open the oven door and remove the food.

TIPS FOR HEALTHY COOKING

When cooking fatty foods in the BAKE and CONVECTION functions, we recommend setting the food directly on the grill inserted in position 2 and with the pan in position 1.

In this manner the excess grease will be deposited in the pan.

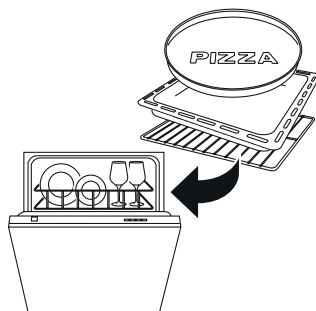
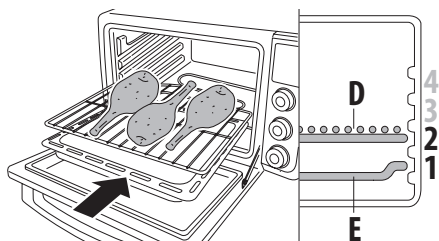

- Remove the crumb tray (R) from the bottom of the oven.

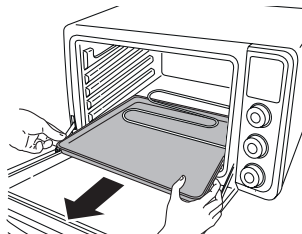

CLEANING AND MAINTENANCE

Frequent cleaning avoids the creation of smoke and unpleasant odours during cooking. Do not allow grease to accumulate in the appliance.

- Before any maintenance or cleaning operate, unplug the oven and allow it to cool.
- Clean the door, the inside walls and the external surfaces of the oven with a solution of water and neutral detergent, and dry well.
- Do not use harsh, acidic, or aggressive detergents, flammable liquids, scouring pads or pointed metal tools for cleaning. Never submerge the appliance in water or wash it with jets of water.



Make sure no water or liquid soap penetrates the vents on top of the oven.

- The accessories can be washed by hand or in the dishwasher except for the crumb tray that must be handwashed and dried well.

Wash by hand. If there is any residue that is difficult to remove, rinse the tray with hot, soapy water and, if necessary, clean gently with a sponge, without scratching it.

- When the oven is in operation, the internal light (B) is always on.

To replace the light bulb, proceed as follows: unplug the oven, unscrew the glass cover, and replace the light bulb with a new one of the same type (resistant to high temperatures) and then replace the glass cover. (type of light bulb: E14, 15W, 300 °C).

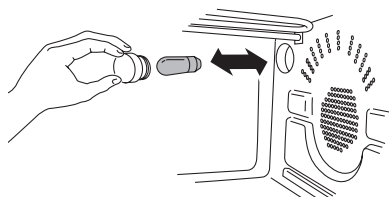





DISPOSAL



Do not dispose of the appliance with domestic waste but deliver it to an authorized sorted waste or recycling centre.

OPERATIONAL ANOMALIES

ERROR MESSAGES ON THE DISPLAY	DESCRIPTION	POSSIBLE PROBLEM	SOLUTION
E0:11 Err	Temperature probe malfunction	The electronic controller has detected a temperature probe malfunction	Write down the error number. Reset the controller by pressing the on/stand-by button  (N) for 2 seconds and unplug. The temperature probe may be damaged. Contact an authorized DeLonghi service centre and give them the error number.
E0:12 Err	Temperature probe malfunction	The electronic control has detected a temperature probe malfunction	Write down the error number. Reset the controller by pressing the on/stand-by button  (N) for 2 seconds and unplug. The temperature probe may be damaged. Contact and authorized DeLonghi service centre and give them the error number.
E0:21 Err	Set temperature has not been reached The oven was not able to reach the set temperature in a reasonable amount of time	The electronic controller detected an excessive amount of time to reach the set temperature inside the oven chamber.	Write down the error number. Reset the controller by pressing the on/stand-by button  (N) for 2 seconds and unplug. First, make sure that the oven door was closed properly during operation. If the door is kept open during operation, the oven cannot reach the set temperature. If, however, the door was closed properly, the heating elements may be damaged. Contact an authorized DeLonghi service centre and give them the error number.
E0:22 Err	Overheating The oven temperature is too high.	The electronic controller detected an overly high temperature inside the oven chamber.	Write down the error number. Reset the controller by pressing the on/stand-by button  (N) for 2 seconds and unplug. The electronic controller on the oven may be damaged. Contact an authorized DeLonghi service centre and give them the error number.
E0:27 Err	Unexpected heating The temperature probe detected a temperature increase even though the heating elements were off.	The electronic controller detected Unexpected heating inside the chamber while the heating elements were off.	Write down the error number. Reset the controller by pressing the on/stand-by button  (N) for 2 seconds and unplug. This error can occur if the DEFROST function was started while the oven was still hot from a previous use. Make sure the oven is completely cool before starting the DEFROST function. If the DEFROST function was not used, the electronic controller could be damaged. Contact an authorized DeLonghi service centre and give them the error number.

POSSIBLE PROBLEM	SOLUTION
The oven does not turn on.	<ul style="list-style-type: none"> - Make sure the plug is fully inserted in the outlet. - Plug into another outlet. - Make sure the switch is working properly. <p>If these solutions did not solve the problem, the oven has probably malfunctioned. Contact an authorized DeLonghi service centre</p>
The display light is off.	<p>The electronic controller on the oven has gone into stand-by mode after a period in which it was not used if the time of day has not been set. When the time of day is set, the display light is always on.</p>
The time of day has disappeared.	<p>If the time of day that was previously set has disappeared, there was a power outage that lasted more than 5 seconds. The electronic controller has reset. Reset the time of day.</p>
The oven light stays off when the oven is on.	<ul style="list-style-type: none"> - The light bulb is burnt out. Replace it. - The light bulb is not installed properly. Make sure the light bulb is screwed in tightly. <p>If these solutions did not solve the problem, the light control has probably malfunctioned. Contact an authorized DeLonghi service centre</p>
Pizza does not cook uniformly.	<p>Some very large pizzas or those with special doughs and ingredients may have a cooking uniformity problem. We suggest turning the pizza during cooking for a good final result.</p>
Steam escapes from the oven openings.	<p>This is normal. The oven has vents to expel excess humidity created by particularly wet foods.</p>
There are drops of water on the internal surface of the door glass.	<p>This is normal. The condensation generated by particularly wet foods runs off the surface of the glass and is collected in a special guide in the area below the inside of the door.</p>

RECIPES

FRESH PIZZA

Ingredients:	Quantity:
water	200 g
fresh yeast	7 g
White flour W330 (or Manitoba type 0)	210 g
durum wheat flour	50 g
extra virgin olive oil	15 g
salt	6 g
mozzarella	100 g
tomato sauce	
salt	to taste
oregano	to taste

1. Prepare the pizza dough: dissolve the yeast in water in the mixer bowl, add the flour and mix for 7-8 minutes, removing the dough from the hook with a spatula every once in a while.
2. Add the salt a bit at a time and then add the oil in a stream. When the oil has been completely absorbed, set the dough on an oiled surface and form into a ball using your hands.
3. Place it in a large, lightly oiled bowl, cover with plastic wrap or with a clean cloth and let rise in a warm place away from air currents.
4. Wait until the dough has at least doubled in volume (about an hour and a half) and then spread out the pizza. Place the dough on a lightly floured surface and spread out using your hands. Thoroughly oil the pizza plate provided, spread the dough over it and top with the tomato sauce, a pinch of salt, and the oregano.
5. Insert the pizza plate in the oven above the grill inserted in guide 1. Select the PIZZA function, set the weight to 800 g and press the START button (H).
6. At 6 minutes from the end, the oven will beep. Add the cubed mozzarella and continue cooking.
7. When finished cooking, serve.

LASAGNE ALLA BOLOGNESE

Ingredients:	Quantity:
Fresh lasagna,	10 sheets
Béchamel	1 l
meat sauce	500 g
parmigiano cheese	100 g

1. First prepare the meat sauce and Béchamel separately.
2. Now start putting the lasagna together in a 30x20 cm rec-

tangular baking dish. Spread a layer of Béchamel sauce in the dish, making sure it is uniform and covers the entire surface. Place a layer of lasagna noodles and then another thin layer of Béchamel sauce.

3. Now spread a layer of meat sauce and the grated cheese, making sure you cover the entire surface of the dish. Continue in layers until you have used all of the ingredients. Finish with a layer of meat sauce and a thick sprinkling of parmigiana cheese.
4. Select the BAKE function, set the temperature to 180°C and the time to 40 minutes then press the START button (H). The oven starts the pre-heating phase. Once the temperature is reached the display will show the cooking time. Insert the tray above the grill inserted in guide 1 and cook for the set time.
5. At the end, take it out of the oven and allow to cool before serving.

CHICKEN ROULADES STUFFED WITH CHEESE AND SPINACH

Ingredients:	Quantity:
chicken breast	4
sliced cheese	2
precooked spinach	200 g
extra virgin olive oil	to taste
salt and pepper	to taste
sage leaves	to taste
rosemary	to taste

1. Beat each chicken breast lightly with the meat tenderizer. Season with salt, pepper, and minced rosemary and sage. On each one place spinach and the cheese slices cut into strips.
2. Roll up the chicken slices and fasten with a toothpick or some kitchen twine.
3. Cover the pan with baking paper and place the roulades on top.
4. Select the CONVECTION function, set the temperature to 180°C and the cooking time to 30 minutes. Press the START button (H). The oven starts the pre-heating phase.
5. Once the temperature is reached the display will show the cooking time. Insert the pan in guide 2 and cook for the set time.
6. Serve sliced.

ROASTED PORK SHANK WITH SESAME POTATOES AND GINGER ONION CREAM

Ingredients:	Quantity:
Pork shank	
(2 whole, cut in half length-wise)	1.4 kg
organic red potato	500 g
mix of celery, carrot, and onion	to taste
garlic,	2 pc.
Dijon mustard,	1 Tablespoon
cloves	6
sage, rosemary	to taste
extra virgin olive oil	3 g
onion	150 g
fresh ginger	30 g
salt and pepper	to taste

1. One day ahead of time (recommended), marinate the shanks with the mustard, 2 tablespoons of oil, the ground cloves, garlic, aromatic herbs, a glass of dry white wine, salt, and pepper.
2. Mince the carrots, celery, and onion then mix it with the meat and put everything on the pan.
3. Insert the pan in guide 1, close the door, and set the oven in KEEP WARM function for 4 hours.
4. In the meantime, wash the potatoes in baking soda then cut them in 3x3 cm cubes.
5. Boil the potatoes in salted water until al dente then remove them and season with salt, pepper, oil, and sesame oil.
6. Chop the onions and cook in 500g of water until creamy then add the grated ginger and sprinkle in the rice flour and blend well. Add salt if necessary. The sauce must have a creamy consistency. If necessary, reduce it over heat.
7. Remove the shanks from the oven then remove and set aside the vegetables and cooking juices. Add the potatoes to the pan
8. Blend the drippings previously left aside with a small amount of extra virgin olive oil.
9. Select the CONVECTION function, set the temperature to 220°C and the cooking time to 30 minutes. Press the START button (H). The oven starts the pre-heating phase.
10. Once the temperature is reached the display will show the cooking time. Insert the pan in guide 2 and cook for the set time.
11. Once the shanks are brown, remove them from the oven and serve with the two prepared sauces.

MEDITERRANEAN SEA BREAM

Ingredients:	Quantity:
sea bream	2
cherry tomatoes	200 g
Taggiasca olives	100 g
1 garlic clove	
thyme	to taste
salt	to taste
pepper	to taste
olive oil	to taste

1. First remove the scales from the sea bream, wash and dress. Salt and pepper inside the belly, add a clove of garlic and two sprigs of thyme.
2. Pour the oil inside the tray and arrange the two sea bream on top.
3. Cut the cherry tomatoes in half and put them inside the tray along with the black olives then sprinkle everything with salt.
4. Select the BAKE function, set the temperature to 200°C and the cooking time to 35 minutes. Press the START button (H). The oven starts the pre-heating phase.
5. Once the temperature is reached the display will show the cooking time. Insert the pan in guide 2 and cook for the set time.
6. Serve.

JAM TART

Ingredients:	Quantity:
flour	250 g
sugar	110 g
butter	125 g
eggs	1 whole + 1 yolk
salt	1 pinch
jam	200 g

1. Mix all of the ingredients (except the jam) in a food processor. Put about 1/3 of the dough aside to use as decoration.
2. Roll out the rest of the dough and line a previously buttered and floured cake tin.
3. Add the jam and use the rest of the dough to decorate with criss-crossed strips.
4. Select the BAKE function, set the temperature to 180°C and the cooking time to 35 minutes. Press the START button (H). The oven starts the pre-heating phase.
5. Once the temperature is reached the display will show the cooking time. Insert the cake tin above the grill inserted in guide 1 and cook for the set time.

SPONGE CAKE

Ingredients:	Quantity:
eggs	6
sugar	190 g
flour 00	150 g
potato starch	75 g
vanillin	2 g

1. Beat the eggs and sugar in a bowl until they are thick and foamy. Now add the sifted flour, starch and vanillin and mix with a whisk until completely mixed, making sure not to whip it.
2. Butter and flour a 26 cm cake tin and pour the batter in the centre, making sure it is level.
3. Select the BAKE function, set the temperature to 170°C and the cooking time to 30 minutes. Press the START button (H). The oven starts the pre-heating phase.
4. Once the temperature is reached the display will show the cooking time. Insert the cake tin above the grill inserted in guide 1 and cook for the set time.

PLUM CAKE

Ingredients:	Quantity:
butter	250 g
sugar	250 g
eggs	3 whole + 2 yolks
Flour	250 g
raisins	80 g
rum	1 cup
salt	1 pinch

1. Cream the butter (which must be removed from the refrigerator at least 2 hours ahead of time) with the sugar until the batter is white.
2. Add the eggs one at a time, then at the flour a little at a time and a pinch of salt. Then add the rum and raisins (after soaking for 30 minutes in warm water).
The raisins must be squeezed dry and then floured so they do not fall to the bottom of the tin during cooking.
3. Pour the mixture into a rectangular pan that was previously buttered and floured.
4. Select the BAKE function, set the temperature to 150°C and the cooking time to 90 minutes. Press the START button (H). The oven starts the pre-heating phase.
5. Once the temperature is reached the display will show the cooking time. Insert the plum cake pan above the grill inserted in guide 1 and cook for the set time.

CHOCOLATE-NUTS CHIPS COOKIES

Ingredients:	Quantity:
peeled hazelnuts	110 g + 50 g
brown sugar	50 g
soy milk	50 ml
faro flour	25 g
powdered cocoa	5 g
corn starch	10 g
dark chocolate chips	15 g

1. Chop the hazelnuts with the sugar in the food processor until very fine
2. Sift the flour with the starch and cocoa then add the chopped hazelnuts and then the chocolate. Add the soy milk and mix the dough until it is smooth and wet.
3. Put the bowl in the refrigerator for at least an hour to thicken the dough so that it can be worked by hand.
4. Work the dough, making strips and then chunks of dough that should be shaped into spheres and put on two grills with baking paper. Flatten the balls with a fork and sprinkle hazelnuts on top.
Select the COOKIES function and set 2P.
Press the START button (H).
5. When the temperature has been reached the oven will go into stand-by mode and the cooking time will flash on the display. Insert the grills in guides 1 and 3, set 20 minutes and press the START button (H).
6. About halfway through cooking the oven will beep and the cooking time will flash. Swap the two grills and press the START button (H).
7. Serve the cookies.