

Proudly distributed by  
**De'Longhi Australia Pty Limited**  
P.O. BOX 4540  
CASULA MALL NSW 2170  
Customer Service Ph: 1800 126 659  
Fax: 1800 706932  
[www.delonghi.com.au](http://www.delonghi.com.au)  
e-mail: [info.au@delonghigroup.com](mailto:info.au@delonghigroup.com)

**De'Longhi New Zealand Limited**  
99 Khyber Pass Road  
Grafton 1023  
Auckland  
New Zealand  
P.O. Box 58-056 Botany  
MANUKAU 2163  
Customer Service Ph: 0508 200 300  
Fax: 0508 200 301  
[www.delonghi.co.nz](http://www.delonghi.co.nz)  
e-mail: [info.nz@delonghigroup.com](mailto:info.nz@delonghigroup.com)



---

F28313

ELECTRIC DEEP FRYER



---

**DeLonghi**

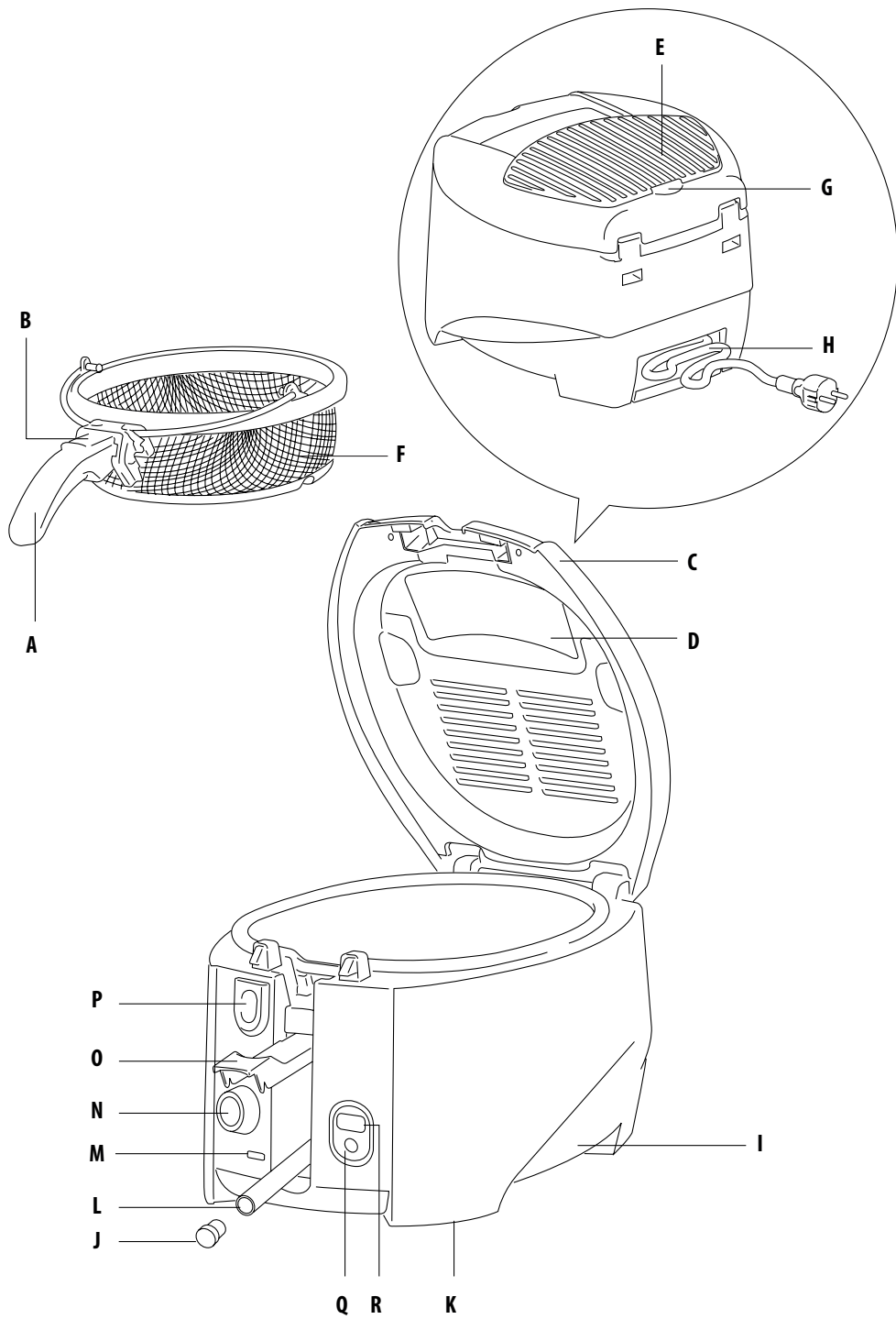

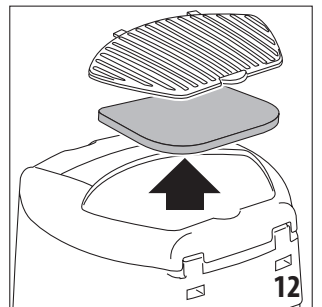
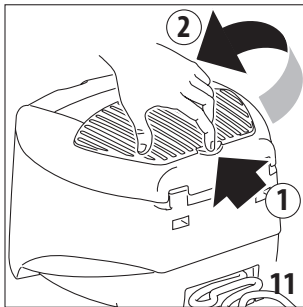
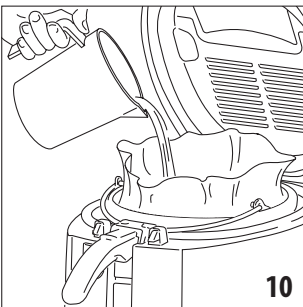
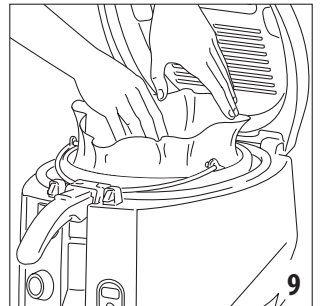
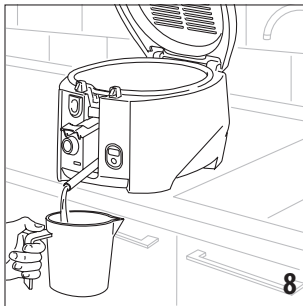
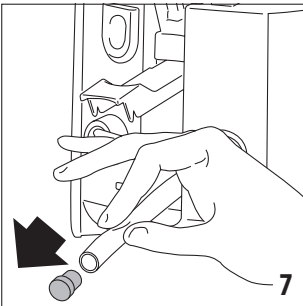
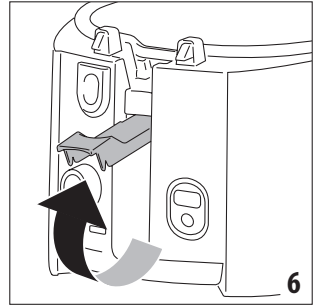
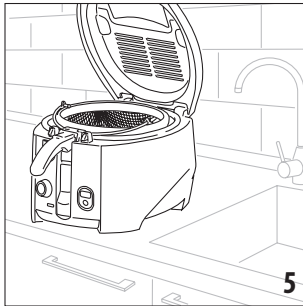
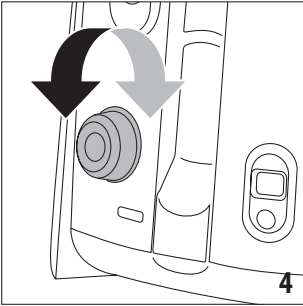
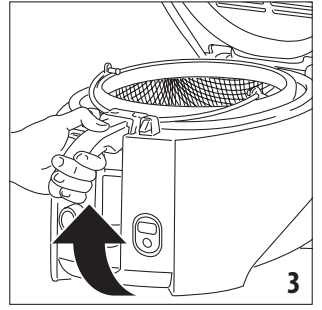
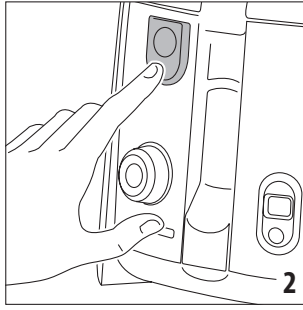
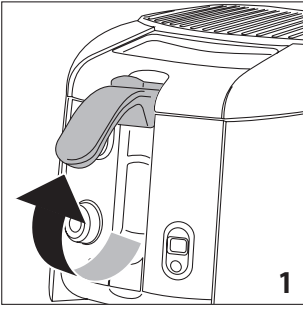

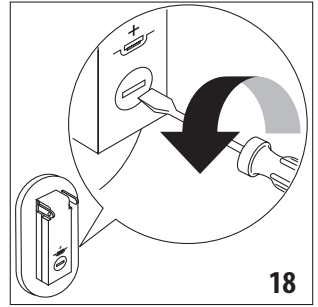
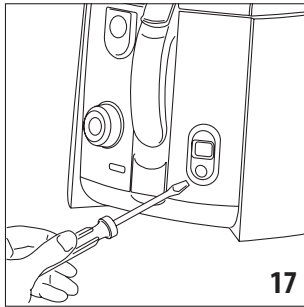
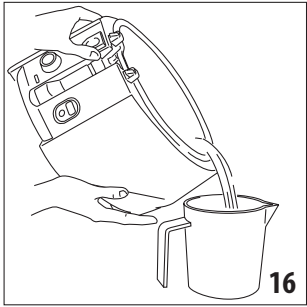
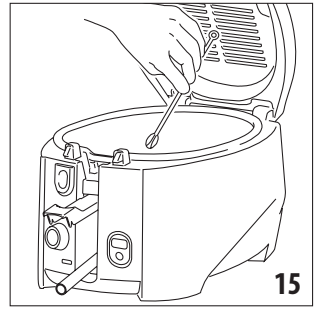
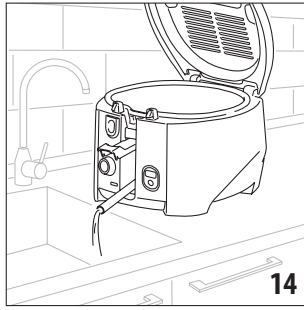
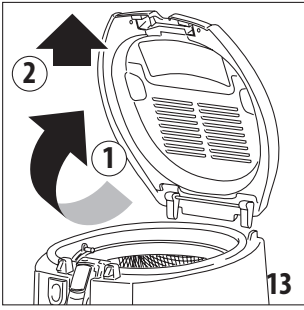

**Read all the Instruction for Use carefully before using the appliance. Keep this Instructions for Use.**

- If the power cable is damaged, it must be replaced by the manufacturer or the manufacturer's Customer Experience in order to avoid all risk.
- Never immerse the appliance in water.
- The appliance is not intended for use by persons (including children) with reduced physical, sensory or mental capabilities, or lack of experience and knowledge, unless they have been given supervision or instruction concerning use of the appliance by a person responsible for their safety.

Children should be supervised to ensure that they do not play with the appliance.

- The appliance must not be operated by a timer or a separate remote control system.
- This is household appliance only. It is not intended to be used in: staff kitchen areas in shops, offices and other working environments; farm houses; by clients in hotels, motels and other residential type environments; bed and breakfast type environments.
- Cooking appliances should be positioned in a stable situation with the handles (if any) positioned to avoid spillage of the hot liquids.



**Danger!**

Failure to observe the warning may result in life threatening injury by electric shock.

- Before use check that the voltage power supply corresponds to the one shown on the appliance data plate.

- Only connect the appliance to electrical sockets which have a minimum load of 10A and which are properly earthed. (If the socket and the plug on the appliance should prove incompatible, get a professionally qualified technician to replace the socket with a more suitable one).



**Danger of burns!**

Failure to observe the warnings could result in scalds or burns.

- The appliance is hot when it is in use. DO NOT LEAVE IT WITHIN THE REACH OF CHILDREN.
- Do not move the deep fryer when the oil is hot, as there it could cause serious burns.
- To move the appliance, use the special lifting handles. (Never lift by the basket handle). Check that the oil is cool enough (waiting about 2 hours).
- Never leave the power cable hanging from the edge of the surface the deep fryer is resting on, where it could be grasped by a child or get in the way of the user.
- When opening the lid, take great care to avoid hot steam and splashes of boiling oil.



**Important!**

Failure to observe the warnings may result in life threatening injury or damage to the appliance.

- Do not place the appliance near heat sources.
- The deep fryer must only be switched on after it has been filled with oil or fat. If it is heated up while empty, a thermal safety device comes into operation which stops it from working. In this case it is necessary to contact our nearest authorised service centre.
- If the deep fryer leaks oil, contact the technical service centre or staff authorised by the Company.



**Please note:**

This symbol identifies important advice or information for the user

- Before using the deep fryer for the first time, wash the pan, the basket and the lid (removing the filter) carefully with hot water and washing up liquid. When this has been done, dry carefully. After washing, dry thoroughly. Remove any water left in the bottom of the container. This avoids dangerous spurts of hot oil during use.
- It is totally normal that, on first use, the appliance emits a "new appliance" smell. If this happens, aerate the room.
- Never use homemade or very acid oils.
- If your appliance has a drain hose, make sure it is always closed and in its compartment while the appliance is in use.
- The basket fits automatically onto the central pin in the bowl.



This appliance conforms to EC Regulation 1935/2004 on materials and articles intended to come into contact with food.

## DISPOSING OF THE APPLIANCE



The appliance must not be disposed of with household waste, but taken to an authorised waste separation and recycling centre.

## DESCRIPTION OF THE APPLIANCE

- A. Basket handle
- B. Handle slide
- C. Lid
- D. Viewing window
- E. Filter cover
- F. Basket
- G. Filter cover catch
- H. Cable compartment
- I. Handgrip to lift the appliance
- J. Drain hose cap (certain models only)
- K. Foot
- L. Oil drain hose (certain models only)
- M. Indicator light
- N. Thermostat dial
- O. Hose compartment door (certain models only)
- P. Release button
- Q. Timer button
- R. Timer display

## TECHNICAL DATA

Net weight	3.5 kg
absorbed power:	see rating label
frequency:	see rating label
voltage:	see rating label

## FILLING WITH OIL OR FAT

- Raise the basket (F) into the top position by pulling the handle (A) upwards (fig. 1).  
ALWAYS raise and lower the basket with the lid closed.
- Open the lid (C) by pressing button (P) (fig. 2).
- Remove the basket by pulling upwards (fig. 3).
- Pour 1.2 l of oil (or 1 kg of fat) into the container.



**Important!** The level of oil should always be between the maximum and minimum marks.

Never use the deep fryer with the oil below the “min” level as this could cause the thermal cutout to trip. To replace, contact an authorised service centre.

For best results, use good quality peanut oil.

Never mix different oils together.

If you are using solid fat, cut into small pieces to avoid the deep fryer heating up without liquid for the first few minutes.

The temperature must be set to 150°C until the fat has melted completely. You can then set the required temperature.

## STARTING FRYING

1. Place the food to be fried in the basket. Never over fill (1 kg max. of fresh potatoes).  
To obtain more even frying you should concentrate the food around the edge of the basket, with less food at the centre.
2. Place the basket in the bowl in the raised position (fig. 3) and close the lid, pressing lightly until it clips into place.  
To avoid splashes of hot oil, always close the lid before lowering the basket.
3. Plug the appliance into the mains socket and turn the thermostat dial (N) to the required temperature (fig. 4).  
When the set temperature is reached, the indicator light (M) goes out.
4. As soon as the light has gone out, immerse the basket in the oil by pushing the slide (B) on the basket handle backwards and slowly lowering the basket itself.
  - It is normal for a considerable quantity of very hot steam to be given off from the filter cover (E) immediately after the basket has been lowered.
  - When cooking begins, immediately after immersing the food in the oil, the inside surface of the viewing window (D) (if present) mists up then clears gradually.
  - It is normally for drops of condensation to form near the basket handle while the appliance is in operation.

## SET THE ELECTRONIC MINUTE TIMER

1. Set the cooking time by pressing the minute timer button. The display will show the minutes set.
2. The numbers will begin to flash immediately. This shows that the cooking time has begun. The final minute is displayed in seconds.
3. If an error is made, a new cooking time can be set by holding the button down for more than 2 seconds. The display will reset and the process can then be repeated from point 1.
4. The minute timer will indicate the end of the cooking time with two series of beeps about 20 seconds apart. To turn the acoustic signal off, press the minute timer button.



**Please note:** the minute timer does not automatically turn the appliance off.

## Replacing the minute timer battery

- Remove the minute timer from its housing by prising it from the lower side (fig. 17).
- Turn the battery cover on the back of the battery anticlockwise (fig. 18) until it comes free.
- Replace the battery with another of the same type (L1131).

 **Please note:** When replacing or disposing of the appliance, the battery must be removed and disposed of according to current legislation as it represents a hazard to the environment.

## END OF FRYING

When the set cooking time has elapsed, raise the basket and check that the food is cooked to the required colour.

You can do this through the viewing window without opening the lid.

If you decide the food is sufficiently cooked, turn the appliance off by rotating the thermostat dial to the "0" position until you hear the internal switch click.

Drain excess oil by leaving the basket in the raised position inside the deep fryer.

## FILTERING THE OIL OR FAT

You are recommended to do this after each frying session as, particularly if coated in breadcrumbs or flour, the particles of food remaining in the liquid tend to burn, causing the oil or fat to alter more rapidly.

Make sure the oil is sufficiently cool (wait about two hours).

## Models without drain hose

1. Remove the lid as shown in fig. 13.
2. Empty the deep fryer by tilting it as shown in fig. 16 and collecting the contents in a container.

## Models with drain hose

Move the front of the deep fryer to the edge of the surface on which it stands, making sure the feet (K) remain resting on the surface (fig. 5).

1. Open the deep fryer lid and remove the basket (fig. 3).
2. Open the door (O) as shown in fig. 6.
3. Remove the drain hose (L).
4. Remove the cap (J) and at the same time squeeze the hose with two fingers to avoid the oil or fat running out until the hose is placed over a container (fig. 7).
5. Run off the oil or fat into a container (fig. 8).
6. Remove any deposits left in the bowl using a sponge or absorbent paper.
7. When you have finished, close the drain hose with the cap and replace in its housing.

 **Important!** Never empty the deep fryer by tilting it or turning it upside down. Always use the drain hose.

- Put the basket back in the raised position and place a filter in the bottom of the basket (fig. 9).  
Filters are available from your local dealer or one of our customer service centres.
- Then pour the oil or fat back into the deep fryer very slowly to avoid it overflowing from the filter (fig. 10).
- The filtered oil can be kept inside the deep fryer.  
However, if you will not be frying again for some time, you should keep the oil in the dark in a closed container to avoid it deteriorating.  
It is good practice to separate oil used for frying fish and oil used for frying other food.  
If you are using fat, make sure it does not cool down excessively or it will solidify.

## MAINTENANCE OF THE ANTI-ODOUR FILTER

Over time, the anti-odour filter inside the lid loses its efficiency. You are therefore recommended to replace it after every 10/15 frying sessions.

To replace, remove the plastic filter grille (figs. 11/12).

## CLEANING

 **Danger!** Before cleaning, always unplug from the mains socket.

Never immerse the deep fryer in water and never place it under running tap water. If water gets into the appliance, it could cause electric shock.

 **Danger of burns!** Check the oil is sufficiently cool (wait about two hours).

Empty the oil or fat as described above in the section "Filtering the oil or fat".

Remove the lid as shown in fig. 13.

To remove the lid, proceed as follows: push it backwards (see arrow "1", fig. 13) and at the same time pull it upwards (see arrow "2", fig. 13).

 **Please note:** Never immerse the lid in water without removing the filter first.

To clean the bowl, proceed as follows:

- Wash the bowl with hot water and washing up liquid, then rinse and dry thoroughly.  
In models with oil drain hose, always use the drain hose to empty the water (fig. 14), then eliminate any water re-



- maining in the oil drain hose.
- Use the brush provided to clean the inside of the drain hose (fig. 15).
  - You should clean the basket regularly, making sure to remove any deposits accumulated in the wheel ring.
  - Dry the outside of the deep fryer with a soft damp cloth to eliminate splashes and drips of oil or condensation.

### **Model with non-stick bowl**

Never use abrasive objects or detergents to clean the bowl. Clean with a soft cloth and neutral detergent only.

### **HOW LONG THE OIL OR FAT LASTS**

---

The level of oil or fat must never fall below the minimum.

Every now and then it must be completely changed.

The life of the oil or fat depends on what foods are being fried.

Food coated in breadcrumbs, for example, dirties the oil more than simple frying. As with any deep fryer, the oil deteriorates after being heated a number of times!

Even if used and filtered correctly, it should therefore be changed completely on a regular basis.

Thanks to the rotating basket, the appliance fries with little oil. This means you save about half the oil used by other deep fryers on the market.

### **CORRECT FRYING**

---

- You should always respect the recommend temperature for the recipe being followed.  
If the temperature is too low, the oil will be absorbed.  
If the temperature is too high, a crust will form immediately and the inside of the food will not be cooked.
- The food being fried must not be immersed in the oil until the oil has reached the correct temperature and the light has gone off.
- Never over fill the basket.  
This could cause a sudden drop in the temperature of the oil and therefore greasier uneven frying.
- If you fry small quantities of food, the temperature of the oil must be set lower than that indicated to avoid the oil boiling fiercely.
- Check that the food is sliced into thin, even pieces. If the slices are too thick, the food will not be well cooked inside, despite its appearance, while even slices will all be perfectly cooked at the same time.
- Dry the food perfectly before immersing it in the oil or fat as moist foods will be less crispy after cooking (especially potatoes). Foods with a high water content (fish, meat, vegetables) should ideally be coated in breadcrumbs or flour before frying. Make sure to remove excess flour or

breadcrumbs before immersing the food in the oil.

## FRYING NON-FROZEN FOOD

Bear in mind that cooking times and temperatures are approximate and must be adjusted according to the quantity of food to be fried and personal tastes.

Food		Max. quantity (g)	Temperature (°C)	Time (minutes)
POTATO CHIPS	Recommended quantity for optimum frying	500	190	7-9
	MAX quantity (safety limit)	1000	190	14-16
FISH	Squid	500	160	9-10
	Waffles	500	160	9-10
	Scampi tails	600	160	7-10
	Sardines	500-600	170	8-10
	Cuttlefish	500	160	8-10
	Sole (3)	500-600	160	6-7
MEAT	Beef cutlets (2)	250	170	5-6
	Chicken cutlets (3)	300	170	6-7
	Meat balls (8-10)	400	160	7-9
VEGETABLES	Artichokes	250	150	10-12
	Cauliflower	400	160	8-9
	Mushrooms	400	150	9-10
	Aubergines	300	170	11-12
	Courgettes	200	170	8-10

## FRYING FROZEN FOOD

Frozen foods are stored at very low temperatures. They therefore lower the temperature of the oil or fat drastically. For best results, never exceed the maximum recommended quantities indicated in the following table. Frozen foods are often covered with a layer of ice. This should be removed before cooking by shaking the basket. Immerse the basket in the oil very slowly to prevent the oil from boiling over.



**Danger of burns!** Before immersing the basket, make sure the lid is tightly closed.

The cooking times are approximate and must be adjusted according to the initial temperature of the food being fried and the temperatures indicated on the packaging of the food.

Food		Max. quantity (g)	Temperature (°C)	Time (minutes)
POTATO CHIPS	Recommended quantity for optimum frying	180 (*)	190	3-4
	MAX quantity (safety limit)	1000	190	16-18
POTATO CROQUETTES		500	190	7-8
FISH	Fish fingers	300	190	4-6
	Shrimps	300	190	4-6
MEAT	Chicken cutlets (3)	200	180	6-8

(\*) Recommended quantity for best frying results. You can, of course, fry a larger quantity of frozen potato chips, but they will be greasier as a result of the sudden drop in oil temperature on immersion.

## TROUBLESHOOTING

---

<b>FAULT</b>	<b>CAUSE</b>	<b>REMEDY</b>
Unpleasant smells	The anti-odour filter is saturated.	Replace the filter.
	The oil has deteriorated.	Replace the oil or fat.
	The cooking liquid is unsuitable.	Use good quality peanut oil.
Oil overflows	The oil has deteriorated and produces too much foam.	Replace the oil or fat.
	You have immersed food which is not sufficiently dry in the hot oil.	Dry the food well.
	Basket immersed too rapidly.	Immerse slowly.
	The oil level in the deep fryer is over the maximum limit.	Reduce the quantity of oil inside the bowl.
The oil does not heat up	The deep fryer has been operated without oil in the bowl, damaging the thermal cutout.	Contact customer services (the device must be replaced).
Only half the basket is fried correctly	The basket is not rotating during cooking.	Clean the bottom of the bowl.
		Clean the wheel ring in the basket.